

10 1/2" ETA 804.112

CT 804112 ESI 458483 02 17.01.2013

10 1/2" Ø 23,30 mm

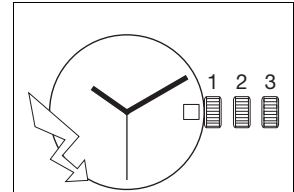

Movement height	Altura sobre máquina	Altezza sopra movimento	3,65 mm
Height on battery	Altura sobre pila	Altezza sopra pila	3,70 mm
Number of jewels	Número de piedras	Numero di pietre	0
Frequency	Frecuencia	Frequenza	32'768 Hz

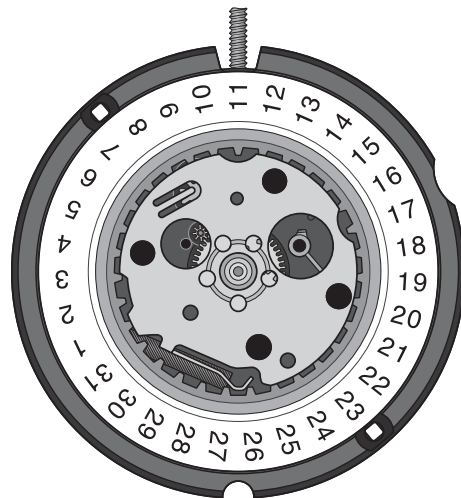
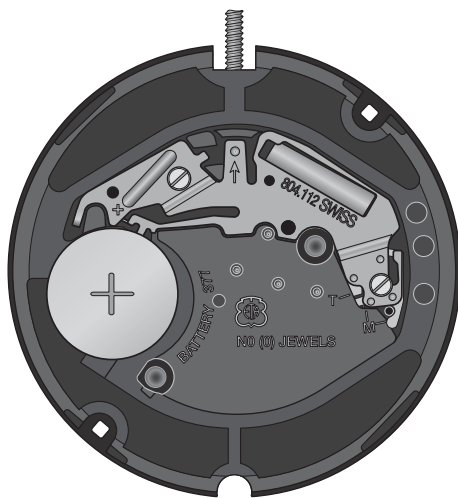

The repair and reconditioning work must only be performed by properly trained personnel.  
Las tareas de reparación y revisión sólo deben ser llevadas a cabo por personal debidamente formado.  
I lavori di riparazione e di revisione devono essere eseguiti esclusivamente da personale adeguatamente formato.



## General information



**Before** starting work, please study this "Technical communication" carefully.



Eye protection is obligatory for all operations / work on the movement!



ETA SA disclaims any liability in case of damage arising from failure to observe this "Technical communication".

## Environmental protection requirements



**The legal provisions relating to waste handling and disposal must be observed in all operations / work on the movement!**

In particular, lubricating and cleaning products harmful to the environment must be disposed of in accordance with the rules!



**Substances prone to cause water pollution** must be stored, transported, collected and disposed of in appropriate vessels.

**Under no circumstances must they pollute the soil or be poured into sewage systems!**

## Explanation of symbols



**Caution! Risk of material damage!**

Below are some obligatory instructions for preventing any material damage!



Below are some instructions for telling which "Specific Information" must be observed.

## Información general



Esta "Comunicación técnica" deberá estudiarse muy bien **antes** de comenzar los trabajos.



Es obligatorio utilizar protección ocular para todos los trabajos en y con el reloj.



ETA SA no se hace responsable de los daños provocados como consecuencia de la inobservancia de esta "Comunicación técnica".

## Normas de protección medioambiental



**Deberá cumplirse la normativa legal relativa al reciclaje y la eliminación correctos de los residuos en todos los trabajos en y con el reloj.**

En especial, deberán eliminarse correctamente los productos lubricantes y de limpieza peligrosos para el medio ambiente.



**Las sustancias contaminantes del agua** deben recogerse, almacenarse, transportarse y eliminarse en recipientes adecuados.

**En ningún caso se permitirá que contaminen el suelo o que lleguen a la canalización.**

## Significado de los símbolos



**Atención Peligro de daños materiales**

Instrucciones que deberán respetarse necesariamente para evitar daños materiales.



Instrucciones para saber qué "Información específica" deberá observarse.

## Informazioni generali



Questa "Comunicazione Tecnica" deve essere studiata attentamente **prima** dell'inizio dei lavori.



Per tutti i lavori su e con il movimento dell'orologio è obbligatorio proteggere gli occhi!



ETA SA declina qualunque responsabilità per eventuali danni causati dalla mancata osservanza della presente "Comunicazione tecnica".

## Disposizioni relative alla protezione ambientale



**Per tutti i lavori su e con il movimento dell'orologio si dovranno rispettare le disposizioni di legge relative al corretto riciclaggio e smaltimento dei rifiuti!**

In particolare si dovrà provvedere al corretto smaltimento di lubrificanti e detergenti nocivi per l'ambiente!



**Le sostanze inquinanti per l'acqua** devono essere conservate, trasportate, raccolte e smaltite in contenitori adatti.

**Queste non devono inquinare il terreno o arrivare nelle canalizzazioni!**

## Spiegazione dei simboli



**Attenzione! Pericolo di danni materiali!**

Seguono importanti indicazioni che devono essere tassativamente rispettate per evitare danni materiali!



Seguono indicazioni su quali "Informazioni specifiche" devono essere rispettate.

## Liste des fournitures - Bestandteilliste - List of components

Pos	No	No CS	Article number Número de artículo Numero articolo	List of components	Lista de piezas	Lista fornitori
1	405	51.020.21	Var	Handsetting stem	Tija de puesta en hora	Albero di messa all'ora
2	4929	20.570.00	7613226081420	Battery	Pila	Pila
			Var	Variante	Variante	Variant

**Interchangeability and variants  
can be found on the  
ETA ONLINE SHOP (EOS):**

**www.eta.ch**

- Support Center
- Support Center Portal

**La intercambiabilidad y las  
variantes se encuentran en  
ETA ONLINE SHOP (EOS):**

**www.eta.ch**

- Support Center
- Support Center Portal

**L'intercambiabilità e le varianti si  
trovano sul  
ETA ONLINE SHOP (EOS):**

**www.eta.ch**

- Support Center
- Support Center Portal

Materials - Fornituras - Forniture

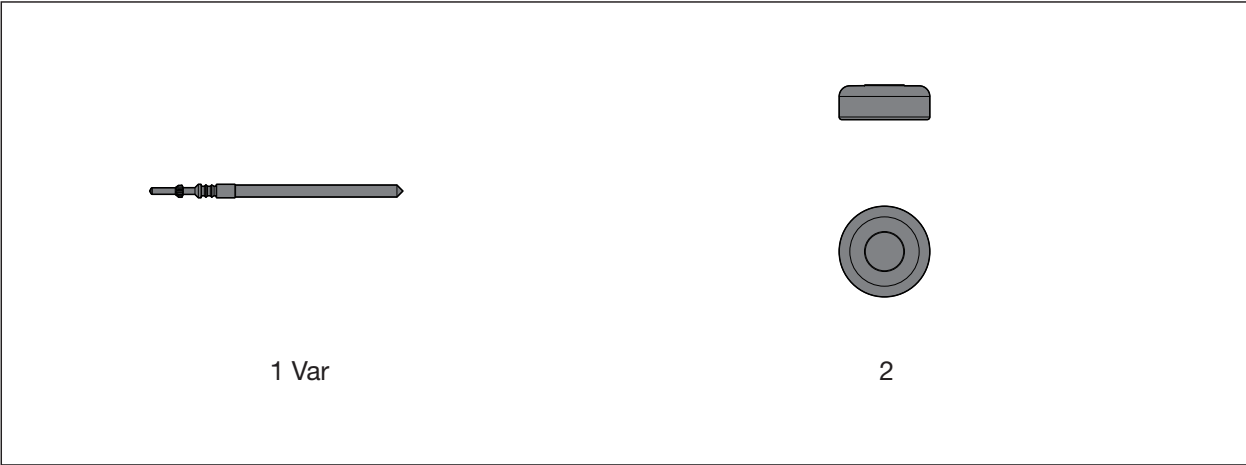

Spare parts - Piezas de repuesto - Pezzi di ricambio:



**Movement undivisible !**  
**Movimiento no desmontable !**  
**Movimento non smontabile !**



- see IS 58.  
- ver IS 58.  
- vedere IS 58.

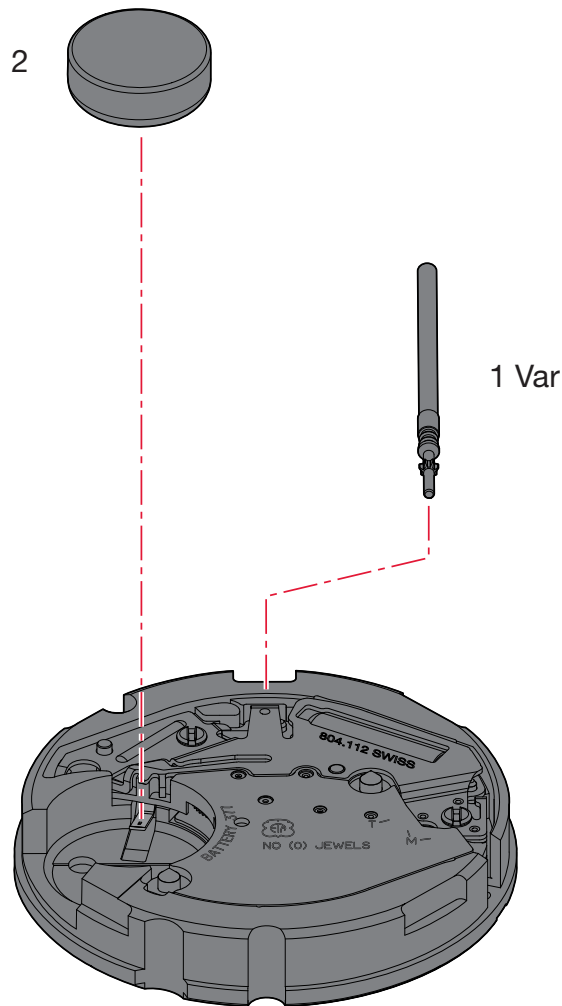

Electrical tests - Controles eléctricos - Controlli elettrici

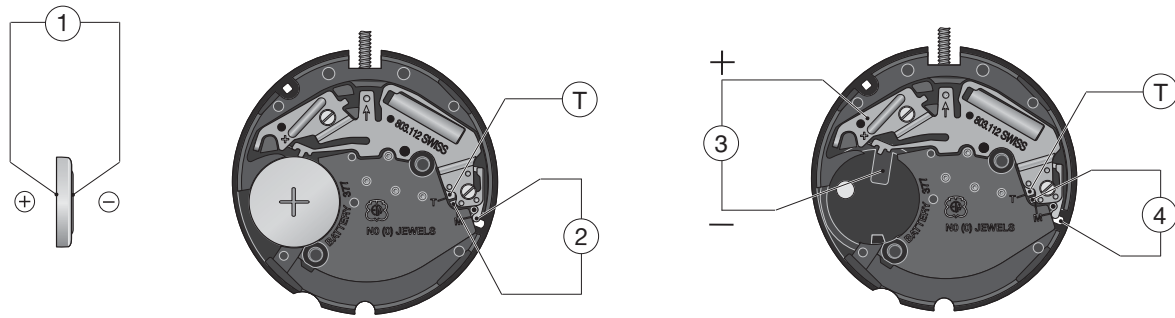

Position Posición Posizione	Setting of apparatus Escala de medición Scala di misura	Measurement Medición Misura	Test Control Controllo	Remarks Notas Osservazioni
1	2 V ( $R_i \geq 10 \text{ k}\Omega/\text{V}$ )	1,55 V	Battery voltage. Tensión de la pila. Tensione della pila.	
2	1 V ( $R_i \geq 10 \text{ k}\Omega/\text{V}$ )	Hand of measuring apparatus oscillates in + and - : 1/s. La aguja del multimetro oscila en sentido + y - : 1/s. La lancetta del multimetro oscilla nel senso + e - : 1/s.	Impulse at output of integrated circuit. Impulsos a la salida del circuito integrado. Impulsi all'uscita del circuito integrato.  1/s	Measurement with controlled battery. Medición con una pila controlada. Misura con una pila controllata.
3	2 V	$\leq 1,30 \text{ V}$ Connect the test point T to the negative pole of the external power supply. Conectar el punto de prueba T con el polo menos de la alimentación externa. Collegare il punto test T con il polo meno dell'alimentazione esterna.	Lower working-voltage limit. Límite inferior de la tensión de funcionamiento. Limite inferiore della tensione di funzionamento.	Measurement without battery, with variable external power supply, starting with 1.55 V, lower tension until movement stops. Medición sin pila, con alimentación exterior variable. Bajando de 1,55 V hasta la parada del movimiento. Misura senza pila, con alimentazione esterna variable, scendendo da 1,55 V fino all'arresto del movimento.
	10 $\mu\text{A}$	Motor driven with 16 steps/s. Motor impulsado por 16 pasos/s. Comando motore a 16 passi.	Consumption of movement with stem in neutral position, at 1.55 V. Consumo del movimiento con la tija en posición neutra, en 1,55 V. Consumo del movimento con albero in posizione neutrale a 1,55 V.	Measurement without battery, with external power supply 1.55 V. Medición sin pila con alimentación exterior de 1,55 V. Misura senza pila con alimentazione esterna di 1,55 V.

Position Posición Posizione	Setting of apparatus Escala de medición Scala di misura	Measurement Medición Misura	Test Control Controllo	Remarks Notas Osservazioni
4	~ 10 k $\Omega$	0,80–1,10 k $\Omega$	<p>Condition of coil. Measurement, recommended voltage 0,2 V. (Ohmmeter).</p> <p>Estado de la bobina Tensión de medición recomendada 0,2 V. (Ohmiometro).</p> <p>Continuità della bobinatura. Tensione di alimentazione 0,2 V. (Ohmmetro).</p>	
	2 mA	180–250 $\mu$ A	<p>Condition of coil. Measurement, recommended voltage 0,2 V. (Amperemeter).</p> <p>Estado de la bobina Tensión de medición recomendada 0,2 V. (Amperímetro).</p> <p>Continuità della bobinatura. Tensione di alimentazione 0,2 V. (Amperometro).</p>	
<p><i>Ohmmeter with a test voltage exceeding 0.40 V unsuitable, recommended voltage 0.20 V.</i>  <i>Ohmiómetros con tensión de medición superior a 0,40 V inapropiados; tensión recomendada 0,20 V</i>  <i>Ohmmetri con tensione di misura superiore a 0,40 V sono inadeguati; tensione raccomandata 0,20 V</i></p>				

Ajustement aiguille des heures  
Stundenzeigerpassung  
Hour hand fitting

Ajustement aiguille des minutes  
Minutenzeigerpassung  
Minute hand fitting

Ajustement aiguille des secondes  
Sekundenzeigerpassung  
Second hand fitting

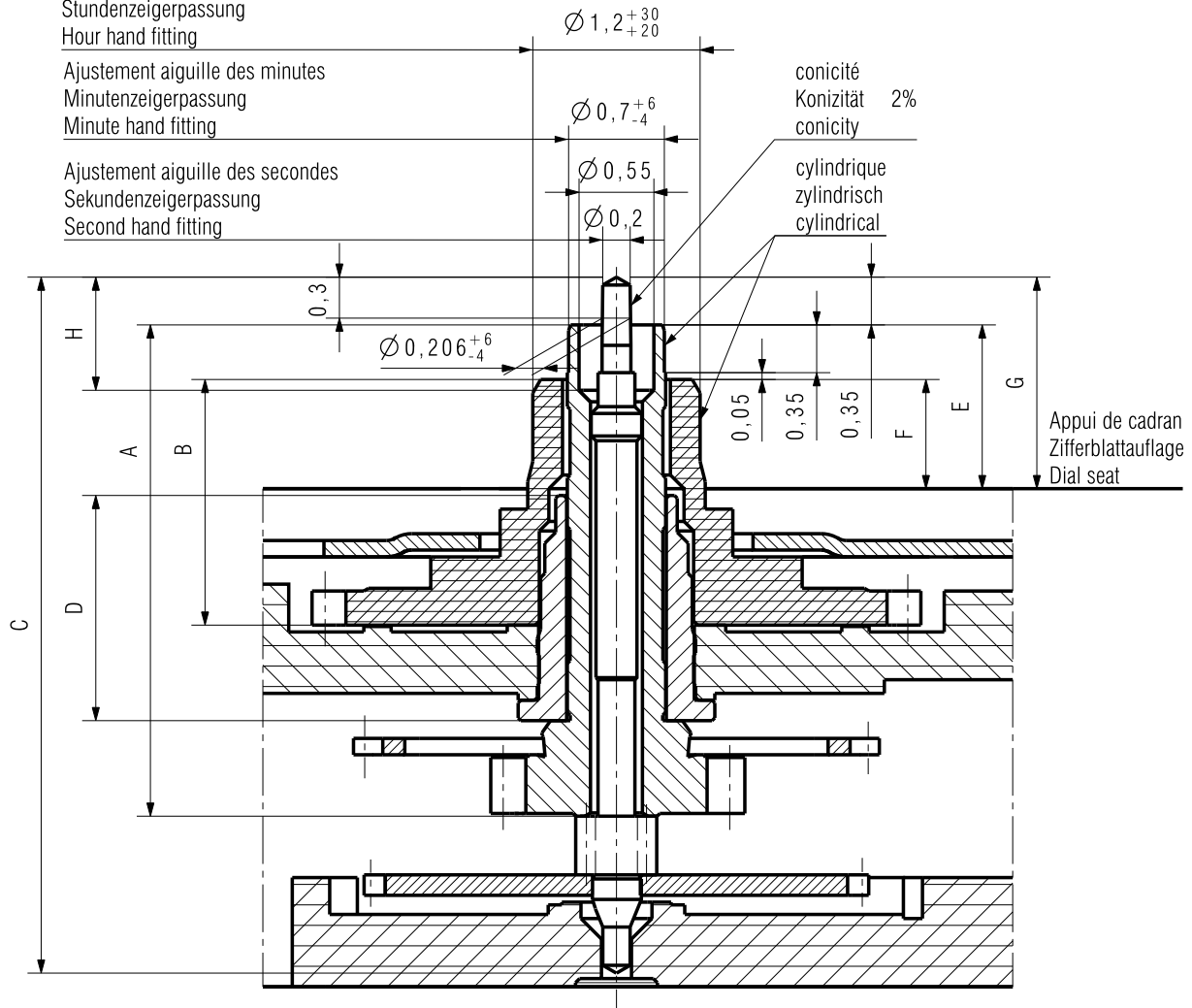

Aiguillage Zeigerwerkhöhe Hand fitting height	Longueur/Länge/Length				Dépassement Höhe über Zifferblattaufage Height over dial seat			H	Ep.cadran Zifferblattdicke Dial thickness
	A	B	C	D	E	F	G		
2	3,6	1,8	5,1	1,65	1,2	0,8	1,55	0,83	

Aiguilles Zeiger Hands	Aiguille d'heure Stundenzeiger Hour hand	Aiguille de minute Minutenzeiger Minute hand	Aiguille de seconde Sekundenzeiger Second hand
Masse/Masse/Mass	max. mg	20	10
Balourd/Unwucht/Unbalance	max. $\mu$ Nm	0,8	0,8
Force de chassage Setzkraft Press-in force	max. N	30	30

Kaliber / Calibre / Caliber 803112 / 804112 / 805112	Masstab Echelle Scale		CATIA V5
		Masse in mm Dimensions en mm Dimensions in mm	Tol.1/1000 mm

AIGUILLAGES ZEIGERWERKHÖHEN HAND FITTING HEIGHTS	Z0242895	Version 00	Revision 00	Blatt Feuille Sheet 01/01
--	----------	---------------	----------------	------------------------------------

<b>ETA SA</b> MANUFACTURE HORLOGÈRE SUISSE DEPUIS 1793  A COMPANY OF THE <b>SWATCH GROUP</b>	Ersatz für/En remplacement de/Remplacement for	Klass. Class.	ZVACC	KUN			
	Aenderung/Modification	Erstellt Etabli Created	Gepüft Contrôle Controlled	Freigegeben Libéré Released			
		08.12.2003	GIR	13.08.2004	CHI	16.08.2004	FEU

We reserve all rights for this document. It is meant for the recipient only and it may not be copied, printed or given to a third person without our written permission. Quedan reservados todos los derechos relacionados con este documento. Queda por lo tanto prohibida su copia, impresión a terceros sin nuestra autorización por escrito. Ogni diritto su questo documento è riservato. Il documento è indirizzato esclusivamente al destinatario e non può essere copiato, stampato o ceduto a terzi senza un'autorizzazione scritta.



This page has deliberately been left blank in case of A3 format printing.

Esta página se han dejado en blanco a propósito en caso de imprimirla en formato A3.

Questa pagina è lasciata intenzionalmente bianca in caso di stampa formato A3.

This page has deliberately been left blank in case of A3 format printing.

Esta página se han dejado en blanco a propósito en caso de imprimirla en formato A3.

Questa pagina è lasciata intenzionalmente bianca in caso di stampa formato A3.

This page has deliberately been left blank in case of A3 format printing.

Esta página se han dejado en blanco a propósito en caso de imprimirla en formato A3.

Questa pagina è lasciata intenzionalmente bianca in caso di stampa formato A3.

**Modifications compared with previous document versions****Modificaciones comparadas con las versiones anteriores del documento****Modifiche comparate con le versioni precedenti del documento**

Version Versión Versione	Date Fecha Data	Modification	Modificación	Modifica	Page Página Pagina
02	17.01.2013	Spare parts	Piezas de repuesto	Pezzi di ricambio	3-5
01	24.11.2009	New layout	Nuevo layout	Nuova layout	1-8
		Allocation per caliber	Asignación por calibres	Ripartizione per calibri	1-8
00	19.09.2007	Basic version	Versión de base	Versione di base	--

All modifications reserved.

Salvo modificación.

Con riserva di ogni eventuale modifica.

This document can be found on the  
Support Center Portal (SCP):

[www.eta.ch](http://www.eta.ch)

- Support Center
- Support Center Portal
- Technical Documents

Este documento se encuentran en el  
Support Center Portal (SCP):

[www.eta.ch](http://www.eta.ch)

- Support Center
- Support Center Portal
- Technical Documents

Il presente documento si trovano sul  
Support Center Portal (SCP):

[www.eta.ch](http://www.eta.ch)

- Support Center
- Support Center Portal
- Technical Documents



**ETA**<sup>SA</sup>  
MANUFACTURE HORLOGÈRE SUISSE  
DEPUIS 1793

SC PRODUCT COMMUNICATION

Bahnhofstrasse 9  
2540 Grenchen  
Switzerland

Phone +41 (0)32 655 71 11  
Fax +41 (0)32 655 71 74

contact@eta.ch  
www.eta.ch